

FRONT VIEW

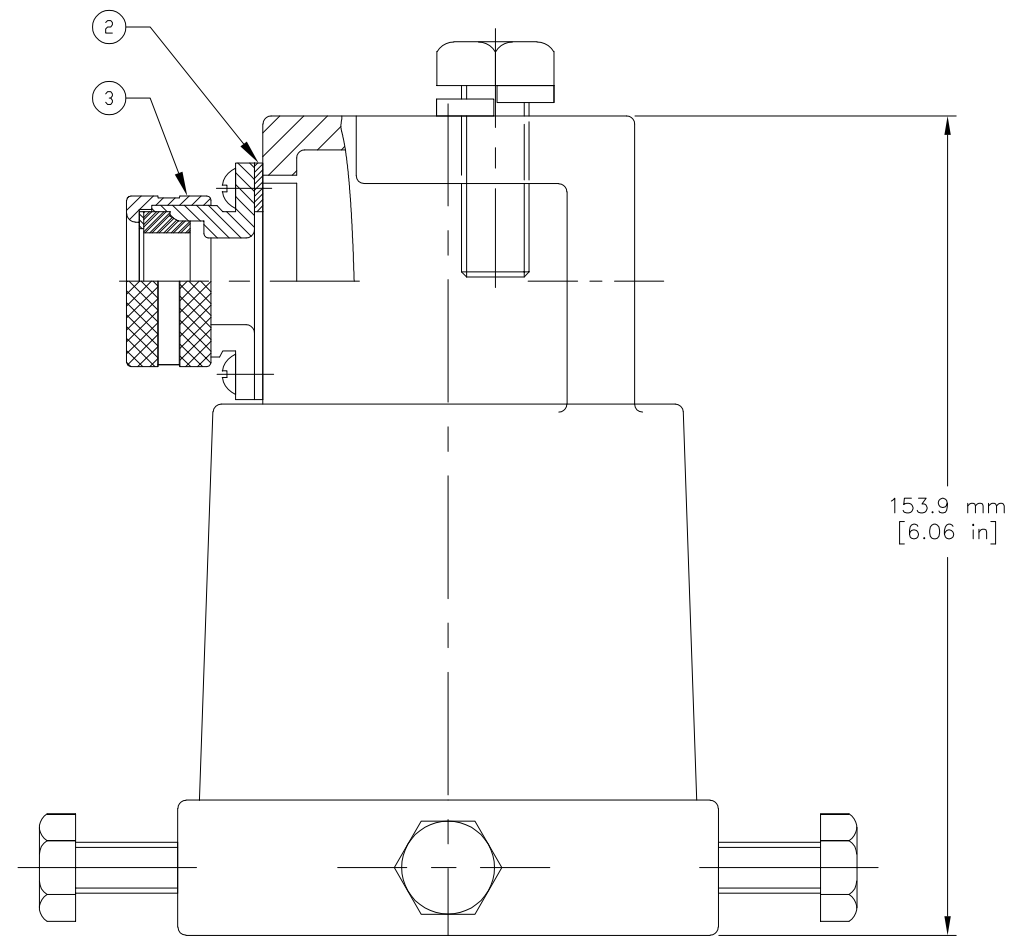

SIDE VIEW

NO.	PARTS	MATERIAL	REMARKS
6	SLIPFITTER MTG BOLTS	STEEL W/ZINC PLATING	59P05672000
5	LOCKWASHER	STEEL W/ZINC PLATING	59W05077000
4	FIXTURE MTG BOLT	STEEL W/ZINC PLATING	59P03802000
3	CONNECTOR CAP	ALUMINUM	59040126000
2	GASKET	RUBBER	59600608000
1	SLIPFITTER	DUCTILE IRON	

CATALOG NO:	GAM8SF
CUSTOMER:	
P.O. NO:	
ITEM NO:	
QUANTITY:	

UNLESS OTHERWISE SPECIFIED
 DIMENSIONS ARE IN INCHES
 DIMENSIONAL TOLERANCES:
 2 PL DECIMALS ±.015
 3 PL DECIMALS ±.005
 ANGLE ±1/2°

Ex DIMENSION	⊕
CTO	◇
REVISION	△

REV.	DATE	MODIFICATION	ECR NO.	DRAWN	CHECKED	REQUESTED
B	27/APR/21	DIMENSIONS ADDED, SELECTION TABLE REMOVED, TEMPLATE UPDATED	-	BEM	VUR	JJV
A	9/13/17	NEW ISSUE	-	JJ	JJ	MARKETING - EH

TITLE: POLE-TOP SLIPFITTER
 CAT. NO.: GAM8SF

MATERIAL:	FINISH:	DATE:
-	-	9/13/17
WEIGHT:	VOLUME:	DRAWN BY:
- lbs	- in ³	JJ
ATEX PART:	CERT. FOLDER NO.	CHECKED BY:
-	-	JJ
		APPROVED BY:
		JJ
		REFERENCE:
		-

EMERSON | APPLETON

This document is the sole property of Appleton Grp LLC and cannot be used, reproduced, transmitted and/or disclosed to any person or companies without its prior permission.

634604 B

APPLETON GROUP LLC