

# Conduit Sealing Bushings

NEC — Suitable for use in the following  
Hazardous Locations:  
Class I, Division 2 per NEC 501.10(B)(4)

## Details of Construction:

### Pressure Discs:

- Thick metal discs with custom drilled holes to accommodate cables. Steel discs are slotted at cable holes to eliminate induction heating effect of single conductor alternating current.
- Steel discs are PVC coated for corrosion protection, to insulate cable holes and to prevent plates from bridging to other ferrous parts. Uncoated aluminum plates are available.

### Screws and Washers:

- Corrosion-proof stainless steel socket head screws are used to compress the two discs against the sealing ring.
- Hex head stainless steel machine screws are available.
- PVC coated discs have stainless steel washers to prevent screws from damaging coating. (Suffix -P type only.)

### CSBG Locking Collar:

- Malleable iron hot dip galvanized.
- Gaskets are provided to prevent locking collar and end of conduit from damaging PVC coated disc. (Suffix -P type only.)

### Sealing Ring:

- Thick one-piece neoprene ring custom drilled. Neoprene is specifically compounded for the following operating characteristics:
  1. Low compression modulus (the ability of the neoprene sealing ring to seal with low-tightening force).
  2. Very low compression set (maintain seal over extended period without having to retighten).
  3. Anti-oxidant (resistance to ozone attack).
  4. Anti-oxidant (resistance to weathering).
  5. Low crystallization (suitable for use at low temperatures).
  6. Fire retardant (will not support combustion).

*For modifications or special requirements,  
contact your local representative for price  
and availability.*

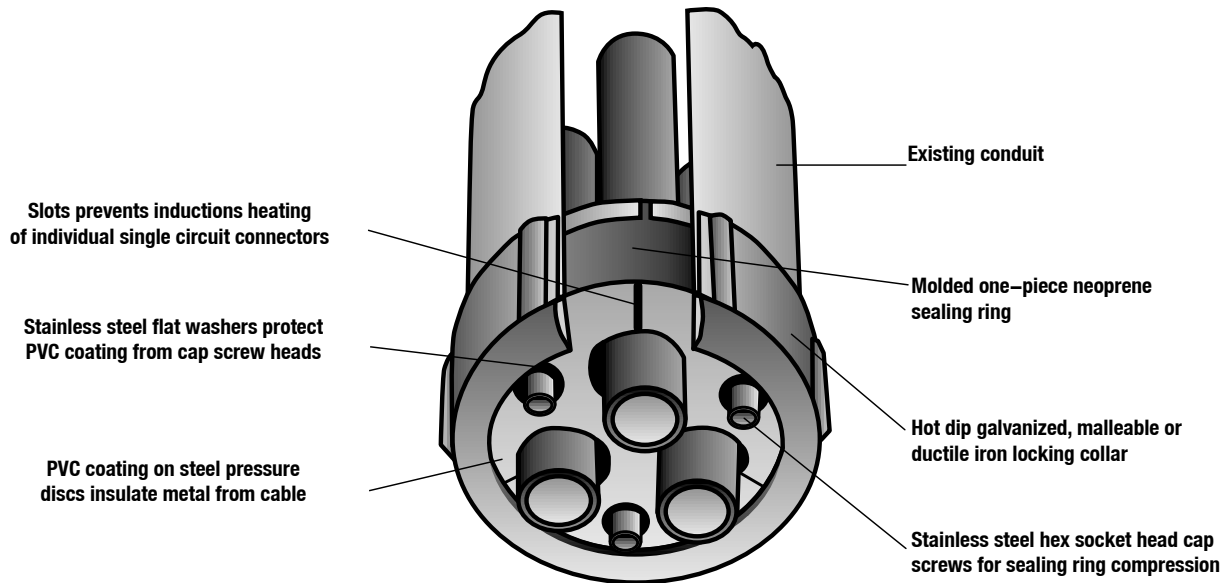

Type CSB  
For use with Cab

# Conduit Sealing Bushings

For Use with Insulated Wire, Cable and Rigid Metal Conduit

NEC — Suitable for use in the following  
Hazardous Locations:  
Class I, Division 2 per NEC 501.10(B)(4)

## Type CSBE:

Seals against internal or external fluids or gases and to provide some support for the cables when fitting is used in vertical position as shown in illustration.

## Type CSBI:

Seals against internal or external fluids or gases and prevents them from entering an enclosure.

## Type CSBG:

Provides all the features of Types CSBE and CSBI and in addition prevents the sealing bushing from moving out of the end of the conduit should the internal pressure be high or if the fitting is used on conduit in an inverted position. The Type CSBG fittings are capable of sealing against gas or fluid pressure of 100 psig, (non-segmented) Type CSBI and CSBE – 50 psig (non-segmented.) Segmenting reduces above pressure in half. Can also be supplied with Lay-In-Lug grounding wire connector.

## Applications

- These conduit Sealing Bushings are used for sealing the ends of conduit in applications involving higher static gas or fluid pressures than can be handled by standard sealing bushings.
- For use with IMC or EMT, a short nipple of Rigid Metal Conduit should be used to accommodate the Conduit Sealing Bushing. For Schedule 40 PVC Conduit, contact your local representative.

## Features

- The complete assembly is provided with 1 or multiple holes to accommodate the size and number of cables which emerge from the conduit. When the fitting is in place and the screws are tightened, the neoprene sealing ring is compressed between the metal plates and is forced against the inside wall of the conduit and also against the cable insulation to effect a complete seal at the conduit end.
- Blank fittings are available. These are intended as abandonment devices only.
- Operating temperature -40 °C to +93 °C (-40 °F to +200 °F)

### Do not field drill.

- Consult your local representative for all other applications.
- These fittings are simple to install. They eliminate the special preparation of the end of the conduit or the compounding of the conduit thread which is required on other types of sealing fittings used to seal against high pressures.

## Standard Materials

- Slotted PVC coated steel discs, neoprene sealing ring and stainless steel socket head cap screws and washers.

## Standard Finishes

- Locking collars on type CSBG - hot dipped galvanized, malleable or ductile iron.

## Options

- Also available with aluminum or brass/ bronze pressure discs (Metal Plates) on Type CSBI and CSBE bushings. To specify, substitute suffix **-A** or **-B** for **-P** in catalog number. (Example: CSBI-200A-1).
- Locking Collar and Pressure Discs are also available in Aluminum on Type CSBG Bushings, add suffix **-A**. Example (CSBG-200A-1).
- Two neoprene sealings rings provide cable support meeting NEC 300.19. (suffix **-G2**)

## Alternate Construction: (Suffix -SEG)

- Segmented Design – Segmental pressure discs and slit-neoprene sealing ring produce a come-apart design which allows the sealing bushing to be installed without having to thread it along the cable or allows installation around cables already pulled/terminated. Example (CSBE-200P-1-SEG)
- Also available with slit neoprene sealing ring and one piece pressure discs. Consult your local representative for price and availability.

## Certifications and Compliances

- UL Listed: E-14817
- Type CSBG with aluminum pressure disks is Listed by Underwriters Laboratories, Inc. as an outlet bushing, service entrance seal or service head.

### TO ORDER SPECIFY:

1. Catalog Number
2. Conduit Size
3. Number of Cables
4. Outside Diameters of Cables Over Insulation
5. Segmented, if required, add suffix **-SEG**.
6. Two Neoprene Sealing Rings, if required (prices on application), add suffix **-G2**.

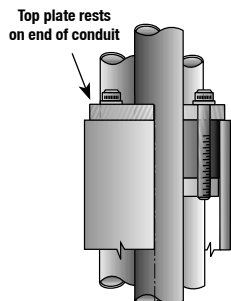

Type CSBE  
(External)

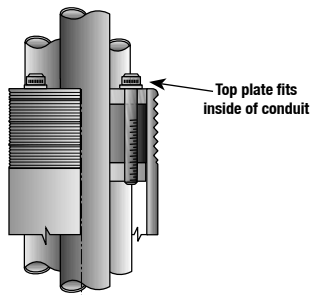

Type CSBI  
(Internal)

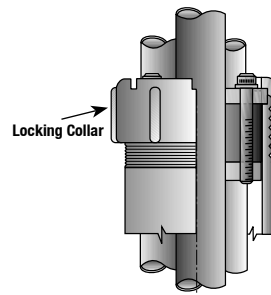

Type CSBG  
(Gland-Locking Collar)

# Conduit Sealing Bushings

For Use with Insulated Wire, Cable and Rigid Metal Conduit

NEC — Suitable for use in the following Hazardous Locations:  
Class I, Division 2 per NEC 501.10(B)(4)

Conduit Size	Max. Diameter of Wire ①				Type CSBE		Type CSBI		Type CSBG	
	Permitted – Inches				Catalog Number		Catalog Number		Catalog Number	
	1 Wire	2 Wires	3 Wires	4 Wires	Blank ②	One or More Wires	Blank ②	One or More Wires	Blank ②	One or More Wires
1-1/2"	19.81 (0.78)	14.99 (0.59)	13.72 (0.54)	11.18 (0.44)	CSBE-150P-0	CSBE-150P-1	CSBI-150P-0	CSBI-150P-1	CSBG-150P-0	CSBG-150P-1
2"	26.67 (1.05)	19.56 (0.77)	18.03 (0.71)	15.49 (0.61)	CSBE-200P-0	CSBE-200P-1	CSBI-200P-0	CSBI-200P-1	CSBG-200P-0	CSBG-200P-1
2-1/2"	33.53 (1.32)	24.38 (0.96)	22.61 (0.89)	19.81 (0.78)	CSBE-250P-0	CSBE-250P-1	CSBI-250P-0	CSBI-250P-1	CSBG-250P-0	CSBG-250P-1
3"	48.26 (1.90)	32.00 (1.26)	28.70 (1.13)	24.38 (0.96)	CSBE-300P-0	CSBE-300P-1	CSBI-300P-0	CSBI-300P-1	CSBG-300P-0	CSBG-300P-1
3-1/2"	54.10 (2.13)	35.05 (1.38)	35.05 (1.38)	28.70 (1.13)	CSBE-350P-0	CSBE-350P-1	CSBI-350P-0	CSBI-350P-1	CSBG-350P-0	CSBG-350P-1
4"	66.80 (2.63)	41.40 (1.63)	38.35 (1.51)	32.00 (1.26)	CSBE-400P-0	CSBE-400P-1	CSBI-400P-0	CSBI-400P-1	CSBG-400P-0	CSBG-400P-1
5"	88.90 (3.50)	50.8 (2.00)	47.75 (1.88)	41.40 (1.63)	CSBE-500P-0	CSBE-500P-1	CSBI-500P-0	CSBI-500P-1	CSBG-500P-0	CSBG-500P-1
6"	114.30 (4.50)	61.98 (2.44)	56.13 (2.21)	52.58 (2.07)	CSBE-600P-0	CSBE-600P-1	CSBI-600P-0	CSBI-600P-1	CSBG-600P-0	CSBG-600P-1

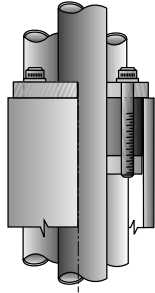

Type CSBE

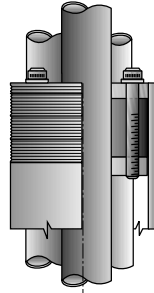

Type CSBI

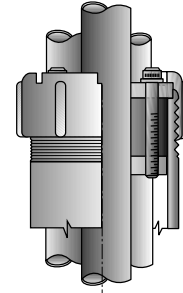

Type CSBG

**TO ORDER SPECIFY:**

1. Catalog Number
2. Conduit Size
3. Number of Cables
4. Outside Diameters of Cables Over Insulation
5. Segmented, if required, add suffix **-SEG**.
6. Two Neoprene Sealing Rings, if required (prices on application), add suffix **-G2**.

① Minimum diameter is 0.140" OD. Five or more wires can be accommodated; contact your local representative for sizing.

② Blank fittings are intended as abandonment and future use devices only. Blank fittings cannot be field drilled.

# Conduit Sealing Bushings

NEC — Suitable for use in the following Hazardous Locations:  
Class I, Division 2 per NEC 501.10(B)(4)

## 1. Segmental Design (Figure 1):

- Segmental pressure discs and slit neoprene sealing ring produce a come-apart design which allows the sealing bushing to be installed without having to thread it along the cable or allows installation around cables already terminated. Maximum diameter of wire or cable may need to be reduced. Must specify suffix **-SEG** after part number. Also available with slit neoprene sealing ring and one piece.

## 2. Double Sealing Ring:

- A second neoprene sealing ring may be added for cable support applications. Add suffix **-G2** to catalog number.

## 3. Type GL Cabinet Adapter (Figure 2):

- For use with sealing bushings when exposed wires enter cabinets. Aluminum material standard. Adapter assembly includes special smooth bore nipple, gasket and locknut. Type GL Cabinet Adapters must be ordered separately. See table below for catalog numbers.
- Temperature Ratings:  
Intermittent -51°C to +107 °C (-60 °F to +225 °F)  
Continuous -40 °C to +93 °C (-40 °F to +200 °F)
- Thread length on special smooth bore nipples will accommodate 1/8" thick cabinet or structure on Type CSBG (specify if thicker than 1/8"), and up to 3/4" thickness on Types CSBE and CSBI.
- These fittings are designed for use in schedule 40 Rigid Metal Conduit. For use with IMC or EMT, a short nipple of Rigid Metal Conduit should be used to accommodate the Conduit Sealing Bushing. Contact your local representative for application involving Schedule 40 or Schedule 80 PVC Conduit.
- Blank fittings are intended as abandonment and future use devices only.

Do not field drill.

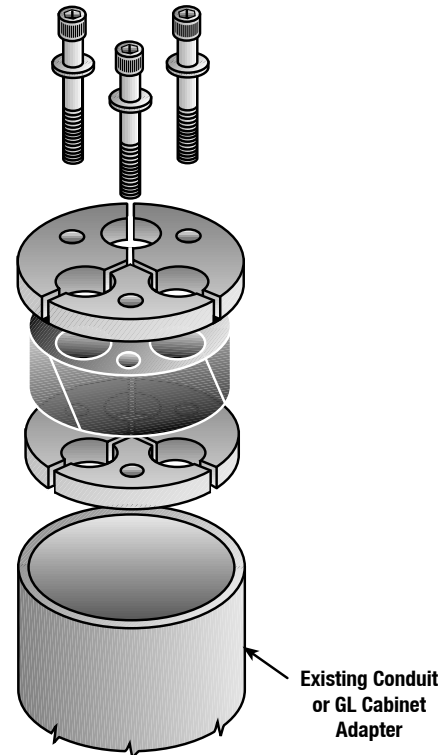

Type CSBE  
Segmental Design  
Figure 1

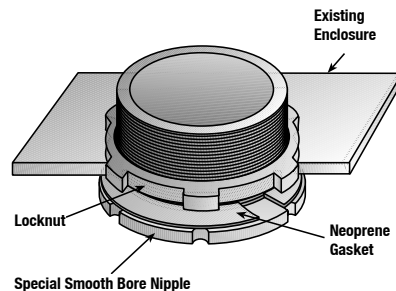

Type GL  
Cabinet Adapter  
Figure 2

Conduit Size	Catalog Number
1-1/2	GL150A
2	GL200A
2-1/2	GL250A
3	GL300A
3-1/2	GL350A
4	GL400A
5	GL500A
6	GL600A

# Conduit Sealing Bushings

For Use with Cable in Rigid Conduit ①

NEC — Suitable for use in the following  
Hazardous Locations:  
Class I, Division 2 per NEC 501.10(B)(4)

## Type CSB Series Dimensional Data:

Conduit ① Size	Max. Diameter of Wire Permitted ② Millimeters (Inches)				Conduit ID	Dimensions in Millimeters (Inches)					
	1 Hole	2 Holes	3 Holes	4 Holes		A Dia.	B	C	D	E	F Min
1-1/2"	19.81 (0.78)	12.45 (0.49)	13.46 (0.53)	11.18 (0.44)	1.610	60.45 (2.38)	16.00 (0.63)	22.35 (0.88)	7.87 (0.31)	7.87 (0.31)	31.75 (1.25)
2"	26.91 (1.02)	19.56 (0.77)	18.03 (0.71)	15.49 (0.61)	2.067	74.42 (2.93)	16.00 (0.63)	22.35 (0.88)	7.87 (0.31)	7.87 (0.31)	31.75 (1.25)
2-1/2"	33.53 (1.32)	24.38 (0.96)	22.61 (0.89)	19.81 (0.78)	2.469	85.85 (3.38)	19.05 (0.75)	22.35 (0.88)	7.87 (0.31)	7.87 (0.31)	31.75 (1.25)
3"	48.01 (1.89)	30.48 (1.20)	28.70 (1.13)	24.38 (0.96)	3.068	104.90 (4.13)	19.05 (0.75)	22.35 (0.88)	7.87 (0.31)	7.87 (0.31)	31.75 (1.25)
3-1/2"	54.10 (2.13)	35.53 (1.32)	35.05 (1.38)	28.70 (1.13)	3.548	115.82 (4.56)	22.35 (0.88)	22.35 (0.88)	11.18 (0.44)	9.65 (0.38)	38.10 (1.50)
4"	66.28 (2.57)	41.40 (1.63)	38.35 (1.51)	32.00 (1.26)	4.026	130.30 (5.13)	7.87 (0.31)	25.40 (1.00)	11.18 (0.44)	9.65 (0.38)	38.10 (1.50)
5"	87.63 (3.45)	50.80 (2.00)	47.75 (1.88)	41.40 (1.63)	5.047	158.75 (6.25)	7.87 (0.31)	25.40 (1.00)	11.18 (0.44)	9.65 (0.38)	38.10 (1.50)
6"	109.73 (4.32)	63.75 (2.51)	60.45 (2.38)	54.10 (2.13)	6.065	187.45 (7.38)	7.87 (0.31)	25.40 (1.00)	11.18 (0.44)	9.65 (0.38)	38.10 (1.50)

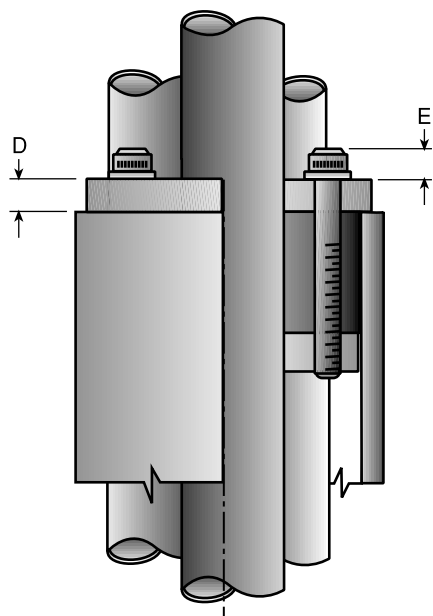

Type CSBE

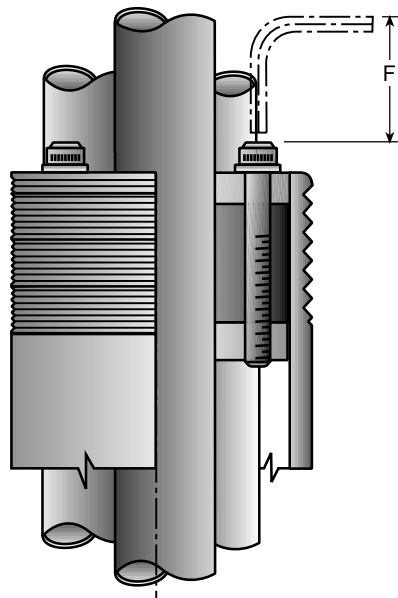

Type CSBI

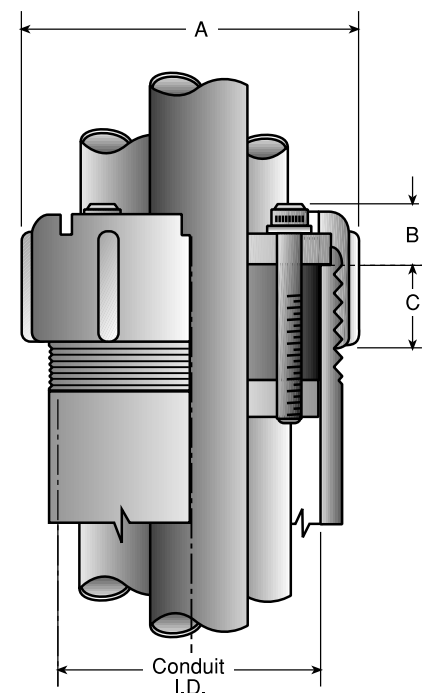

Type CSBG

① Standard fittings may be used with corresponding sizes of schedule 40 pipe or tubes and cored holes which have the same internal diameter as conduit I.D. shown above.

② Minimum diameter is 0.140" OD. Five or more wires can be accommodated; contact your local representative for sizing.

# Conduit Sealing Bushings

NEC — Suitable for use in the following  
Hazardous Locations:  
Class I, Division 2 per NEC 501.10(B)(4)

## Typical Applications

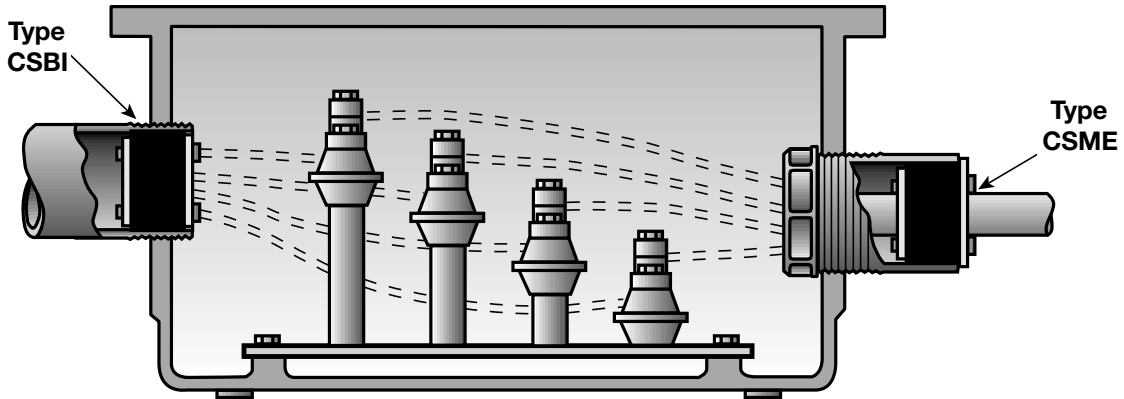

**Type CSBI and Type CSME**  
Used to seal conduits entering an enclosure to prevent condensation and water from entering.

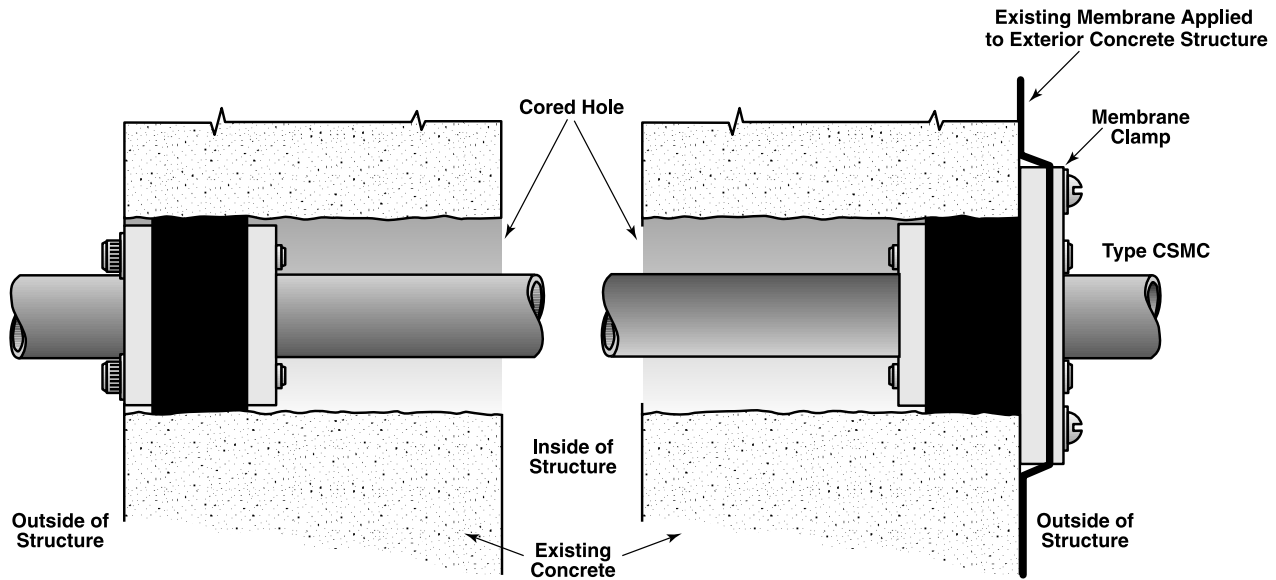

**Type CSMI and Type CSMC**  
Core Drilled Hole Application

COMMERCIAL AND INDUSTRIAL FITTINGS: RIGID AND IMC CONDUIT FITTINGS

# Conduit Sealing Bushings

For Use with Pipe, Conduit or Tubing

NEC — Suitable for use in the following  
Hazardous Locations:  
Class I, Division 2 per NEC 501.10(B)(4)

## Applications

- These Sealing Bushings are used to seal against fluid and gas pressure around mechanical pipes, casing, conduits or tubes
- They have the same details of construction and are used for the same applications as the Type CSB Series.
- In addition to sealing a pipe within a pipe, some types are specifically designed for use in core bit drilled holes or precast holes in concrete.
- Most of the options for the Type CSB are available in the Type CSM Series.

## TO ORDER SPECIFY:

1. Catalog Number
2. Diameter of core bit drilled hole, precast hole or I.D. of pipe.
3. Number and O.D. of penetrating pipe, conduit or tube
4. Disc material finish: PVC Coated Steel Discs (standard); Uncoated Aluminum Discs.
5. Segmented, if required, add suffix **-SEG**.
6. Two Neoprene Sealing Rings, if required (prices on application), add suffix **-G2**.

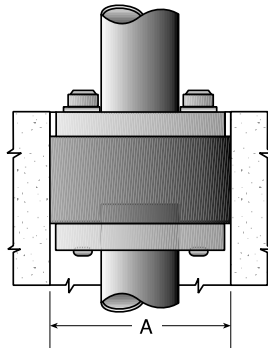

Type CSMI Internal

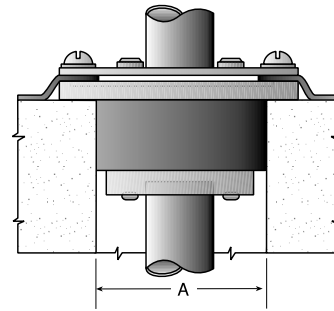

Type CSMC  
with steel membrane clamp  
for holding existing moisture membrane

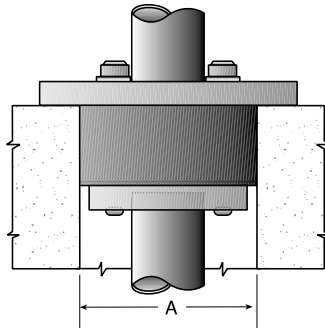

Type CSML Large Top Plate

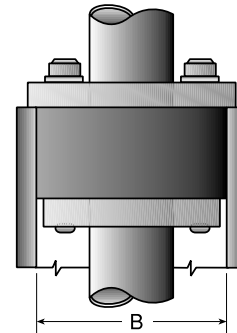

Type CSME External

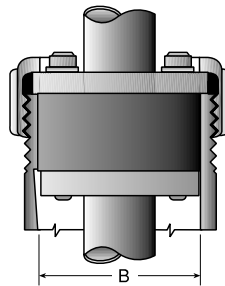

Type CSMG Gland-Locking Collar

# Conduit Sealing Bushings

For Use with Pipe, Conduit or Tubing

NEC — Suitable for use in the following  
Hazardous Locations:  
Class I, Division 2 per NEC 501.10(B)(4)

## Type CSM Series Dimensional Data:

Use With Core Drilled Hole Dia. "A"		Conduit or Pipe I.D. "B"		Single Penetration Applications Dimensions in Millimeters (Inches)						Multiple Penetration Max. O.D. for More Than One Pipe			Catalog Numbers ①				
				Cast Iron Pipe			Copper Tubing			2 Holes	3 Holes	4 Holes	Type CSMI	Type CSML	Type CSMC	Type CSME	Type CSMG
Steel Pipe or Conduit Nom I.D.	O.D.	Nom I.D.	O.D.	Nom I.D.	O.D.	2 Holes	3 Holes	4 Holes	Type CSMI								
										2	52.58 (2.07)	9.65 (0.38)	17.27 (0.68)			9.65 (0.38)	12.70 (0.50)
12.70 (0.50)	21.34 (0.84)			12.70 (0.50)	16.00 (0.63)												
19.05 (0.75)	26.67 (1.05)			19.05 (0.75)	22.35 (0.88)												
2-1/2	62.74 (2.47)	25.40 (1.00)	33.53 (1.32)			25.40 (1.00)	28.70 (1.13)	24.64 (0.97)	23.62 (0.93)	18.54 (0.73)	CSMI-250P	CSML-250P	CSMC-250P	CSME-250P	CSMG-250P		
		31.75 (1.25)	42.16 (1.66)			31.75 (1.25)	35.05 (1.38)										
3	77.98 (3.07)	38.10 (1.50)	48.26 (1.90)			38.10 (1.50)	41.40 (1.63)	30.73 (1.21)	28.19 (1.11)	23.62 (0.93)	CSMI-300P	CSML-300P	CSMC-300P	CSME-300P	CSMG-300P		
		44.45 (1.75)	47.75 (1.88)			44.45 (1.75)	47.75 (1.88)										
		50.80 (2.00)	60.45 (2.38)	50.80 (2.00)	63.50 (2.50)	50.80 (2.00)	54.10 (2.13)	35.05 (1.38)	33.53 (1.32)	28.70 (1.13)							
4	102.36 (4.03)	63.50 (2.50)	73.15 (2.88)	50.80 (2.00)	69.85 (2.75)	50.80 (2.00)	66.80 (2.63)	41.40 (1.63)	37.08 (1.46)	33.53 (1.32)	CSMI-400P	CSML-400P	CSMC-400P	CSME-400P	CSMG-400P		
		76.20 (3.00)	88.90 (3.50)	50.80 (2.00)	69.85 (2.75)	50.80 (2.00)	66.80 (2.63)										
5	128.27 (5.05)	88.90 (3.50)	101.60 (4.00)	76.20 (3.00)	92.96 (3.66)	76.20 (3.00)	96.52 (3.80)	50.80 (2.00)	47.75 (1.88)	41.40 (1.63)	CSMI-500P	CSML-500P	CSMC-500P	CSME-500P	CSMG-500P		
		101.60 (4.00)	114.30 (4.50)	76.20 (3.00)	96.52 (3.80)	76.20 (3.00)	100.58 (3.96)										
		114.30 (4.50)	127.00 (5.00)	101.60 (4.00)	121.92 (4.80)	101.60 (4.00)	127.00 (5.00)										
6	154.18 (6.07)	127.00 (5.00)	141.22 (5.56)	101.60 (4.00)	127.00 (5.00)	101.60 (4.00)	127.00 (5.00)	63.50 (2.50)	54.10 (2.13)	50.80 (2.00)	CSMI-600P	CSML-600P	CSMC-600P	CSME-600P	CSMG-600P		
		152.40 (6.00)	168.40 (6.63)	76.20 (3.00)	100.58 (3.96)	76.20 (3.00)	100.58 (3.96)										
		177.8 (7.00)	152.4 (6.00)	175.26 (6.90)	180.34 (7.10)	177.8 (7.00)	152.4 (6.00)										
10	254.51 (10.02)			177.8 (7.00)	152.4 (6.00)	175.26 (6.90)	180.34 (7.10)	Single Penetration Only			CSMI-1000P	CSML-1000P	②	CSME-1000P	②		
12	303.28 (11.94)	203.20 (8.00)	219.20 (8.63)	203.20 (8.00)	229.87 (9.05)	203.20 (8.00)	236.22 (9.30)	Single Penetration Only			CSMI-1200P	CSML-1200P	②	CSME-1200P			
		254.00 (10.00)	273.05 (10.75)	254.00 (10.00)	289.56 (11.40)	254.00 (10.00)	289.56 (11.40)	Single Penetration Only			CSMI-1400P	CSML-1400P	②	CSME-1400P	②		
14	333.50 (13.13)	304.80 (12.00)	304.80 (12.00)	304.80 (12.00)	335.28 (13.20)	304.80 (12.00)	342.9 (13.5)	Single Penetration Only			CSMI-1600P	CSML-1600P	②	CSME-1600P	②		
		304.80 (12.00)	323.85 (12.75)	304.80 (12.00)	342.9 (13.5)	304.80 (12.00)	342.9 (13.5)	Single Penetration Only			CSMI-1600P	CSML-1600P	②	CSME-1600P	②		

① The suffix -P in the Catalog Number indicates PVC Coated Steel Pressure Discs. For Aluminum Pressure Discs, change P to A.

② Type CSMG and CSMC are not available in these sizes.



# Conduit Sealing Bushings

For Use with Pipe, Conduit or Tubing

NEC — Suitable for use in the following  
Hazardous Locations:  
Class I, Division 2 per NEC 501.10(B)(4)

Use with Core Drilled Hole Dia. Conduit or Pipe I.D.		Single Penetration Applications Dimensions in Millimeters (Inches)						Multiple Penetration Max. O.D. for More Than One Pipe									Catalog No. ②
"A"	"B"	Steel Pipe or Conduit		Cast Iron Pipe		Copper Tubing		2 Holes	3 Holes	4 Holes	C Dia.	D Dia.	E	F	G	H	CSMI- CSML- CSMC- CSME- CSMG-
		Nom I.D.	O.D.	Nom I.D.	O.D.	Nom I.D.	O.D.										
50.80 (2.00)	52.58 (2.07)	9.65 (0.38)	17.27 (0.68)	9.65 (0.38)	12.70 (0.50)	9.65 (0.38)	12.70 (0.50)	20.07 (0.79)	18.03 (0.71)	15.24 (0.6)	76.20 (3.00)	54.10 (2.13)	71.37 (2.81)	33.27 (1.31)	41.40 (1.63)	16.00 (0.63)	200P
63.50 (2.50)	62.74 (2.47)	25.40 (1.00)	33.53 (1.32)	25.40 (1.00)	28.70 (1.13)	25.40 (1.00)	28.70 (1.13)	24.64 (0.97)	23.62 (0.93)	18.54 (0.73)	88.90 (3.50)	65.02 (2.56)	85.85 (3.38)	33.27 (1.31)	41.40 (1.63)	22.35 (0.88)	250P
76.20 (3.00)	77.98 (3.07)	31.75 (1.25)	42.16 (1.66)	31.75 (1.25)	35.05 (1.38)	31.75 (1.25)	35.05 (1.38)	30.73 (1.21)	28.19 (1.11)	23.62 (0.93)	101.60 (4.00)	81.03 (3.19)	104.90 (4.13)	33.27 (1.31)	41.40 (1.63)	22.35 (0.88)	300P
3-1/2 (3.55)	90.17 (3.55)	50.80 (2.00)		50.80 (2.00)	54.10 (2.13)	50.80 (2.00)	54.10 (2.13)	35.05 (1.38)	33.53 (1.32)	28.70 (1.13)	112.78 (4.44)	93.73 (3.69)	115.82 (4.56)	36.58 (1.44)	47.75 (1.88)	22.35 (0.88)	350P
101.60 (4.00)	102.36 (4.03)	50.80 (2.00)	60.45 (2.38)	50.80 (2.00)	63.50 (2.50)	57.15 (2.25)	60.45 (2.38)	41.40 (1.63)	37.08 (1.46)	33.53 (1.32)	127.00 (5.00)	106.43 (4.19)	130.30 (5.13)	36.58 (1.44)	47.75 (1.88)	25.40 (1.00)	400P
127 (5.00)	128.27 (5.05)	63.5 (2.5)	73.15 (2.88)	50.8 (2.00)	69.85 (2.75)			50.80 (2.00)	47.75 (1.88)	41.40 (1.63)	152.40 (6.00)	133.35 (5.25)	158.75 (6.25)	36.58 (1.44)	47.75 (1.88)	25.40 (1.00)	500P
152.40 (6.00)	154.18 (6.07)	88.9 (3.5)	101.6 (4.00)	76.2 (3.00)	92.96 (3.66)	76.2 (3.00)	96.52 (3.8)	63.50 (2.50)	54.1 (2.13)	50.8 (2.00)	179.32 (7.06)	158.75 (6.25)	187.45 (7.38)	36.58 (1.44)	47.75 (1.88)	25.4 (1.00)	600P
203.2 (8.00)	202.69 (7.98)	114.30 (4.5)	127 (5.00)	101.6 (4.00)	121.92 (4.8)	101.6 (4.00)	127 (5.00)	--	--	--	233.43 (9.19)	--	--	36.58 (1.44)	47.75 (1.88)	--	800P ①
254 (10.00)	254.51 (10.02)		177.8 (7.00)	152.4 (6.00)	175.26 (6.9)	152.4 (6.00)	180.34 (7.10)	--	--	--	293.62 (11.56)	--	--	36.58 (1.44)	47.75 (1.88)	--	1000P ①
304.8 (12.00)	303.28 (11.94)	203.2 (8.00)	219.2 (8.63)	203.2 (8.00)	229.87 (9.05)	203.2 (8.00)	236.22 (9.30)	--	--	--	344.42 (13.56)	--	--	39.62 (1.56)	54.1 (2.13)	--	1200P ①
355.6 (14.00)	333.5 (13.13)	254 (10)	273.05 (10.75)	254 (10.00)	289.56 (11.4)	254 (10.00)	281.94 (11.1)	--	--	--	15-9/16	--	--	39.62 (1.56)	54.1 (2.13)	--	1400P ①
406.4 (16.00)	381 (15.00)	304.8 (12.00)	323.85 (12.75)	304.8 (12.00)	335.28 (13.2)	304.8 (12.00)	342.9 (13.5)	--	--	--	17-9/16	--	--	39.62 (1.56)	54.1 (2.13)	--	1600P ①

① Type CSMG and CSMC are not available in these sizes.

② Please add prefix before catalog number to specify fitting type.